

Product Data Sheet Metco 6A Air Control Unit

The Metco™ 6A Air Control Unit is a fully reliable, high quality instrument specifically designed to regulate and filter the compressed air that is required by thermal spray equipment.

The 6A provides accurate adjustment of air pressure to the Metco 3AF flowmeter, and effectively assists in removing oil, water and pipe scale from supply lines. The exclusion of these foreign materials is essential to successful coating application and quality.

1 General Description

The 6A features rugged modular components consisting of two pressure regulator assemblies, and two filters connected in series. The large regulator provides primary air supply for the thermal spray process. It adjusts air pressure to the spray equipment and holds it constant regardless of fluctuations in line pressure. The small regulator provides a secondary supply of air to other equipment, such as air jets, a powder feeder vibrator, 5PVA air vibrator or 3AJ Air Blast Cooler.

One filter is placed ahead of the large regulator to remove oil, water and pipe scale. Air from the small regulator passes through the second filter placed downstream to trap any oil or water that condenses as a result of a pressure drop

through the regulator that could jeopardize coating integrity. The filter bowls, which have a view glass to show the level of trapped liquid, are easy to inspect and clean. They have manual drains to permit removal of the liquid without shutting down.

2 Features and Benefits

- Economical and simple: inexpensive to own and operate; minimal training required.
- Precise: provides specific adjustment of air pressure.
- Versatile: the line pressure tap connects to a secondary air operated device that can properly and safely operate at line pressure.
- Safe: a shut off valve at the outlet side of the unit provides for a quick, easy cutoff of air to the thermal spray equipment.
- Convenient: easily mounts on a wall.
- Easy to monitor: unit has two easily to read pressure gauges and sight glass on filter bowls show levels of trapped contaminants.
- Simple Maintenance: manual drains permit easy removal of the contaminants in filter bowls.
- Rugged design: built for long service life with very little maintenance.
- The 6 A comes assembled with several fittings and elbows to allow easy connection to a variety of air hoses.



6 A Air Control Unit

3 Technical Data

3.1 Dimensions

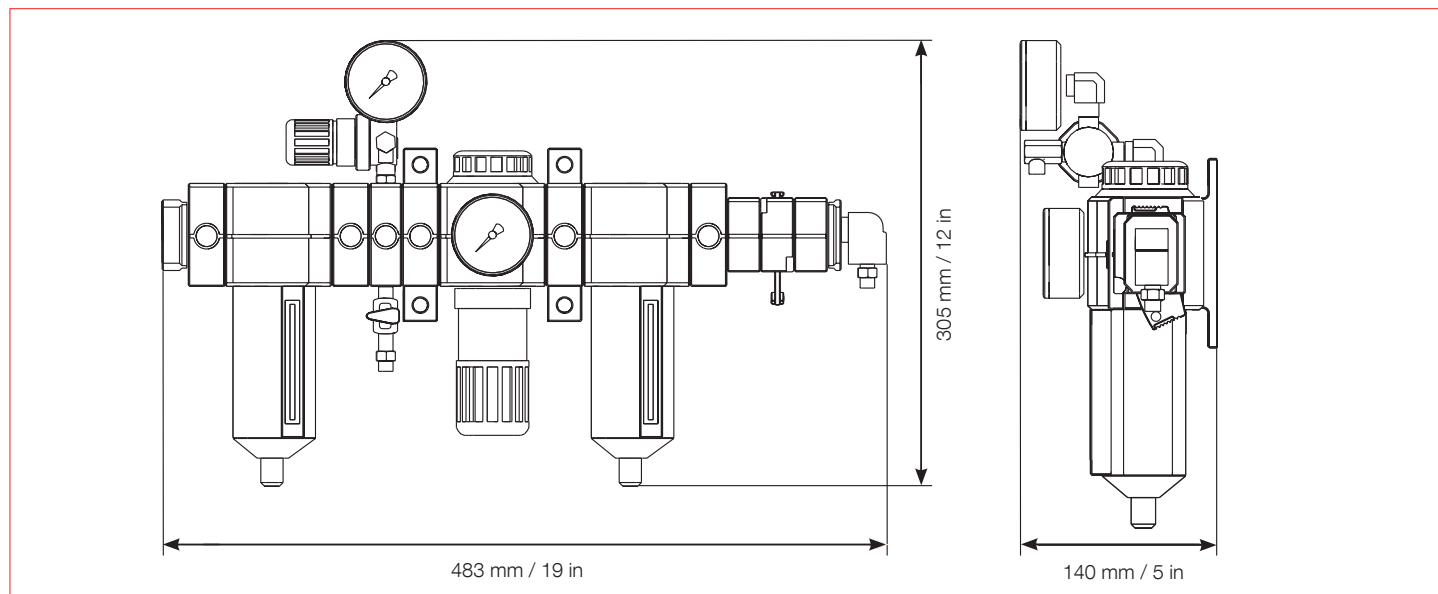

3.2 Specifications

Operating Parameters

Pressure gage units		bar	psi
Flow		942 NLPM	35 SCFM
Inlet pressure	minimum	6.2 bar	90 psig
	maximum	17.2 bar	250 psig
Operating temperature		-18 to 70 °C	0 to 150 °F

Weight

		5 kg	11 lbs
--	--	------	--------

Information is subject to change without prior notice.