

## **Product Data Sheet** WokaJet Series Liquid-Fuel HVOF Spray Guns

**The new Oerlikon Metco WokaJet™-410, WokaJet-410-S and WokaJet-410-Sz guns are rigorously designed for the liquid fuel HVOF spray process. Robust, long-lasting components are used throughout, ensuring long spray runs and low maintenance requirements.**

Oerlikon Metco WokaJet liquid fuel spray guns for HVOF are a proven design using economical kerosene fuel to generate high quality, dense coatings for wear resistance, corrosion resistance and dimensional restoration. Coatings can be very thick and can exhibit favorable compressive stresses that enhance bond and performance in service. WokaJet series guns are rugged, featuring durable, long service life components that can withstand the harshest industrial spray environments, reliably and repeatedly.

The operator-friendly construction of the WokaJet series guns is ideally suited for industrial coating operations and fulfills all the requirements of a modern spray system. The guns are designed for machine mounting and may be fixed on robots, linear traverse units and other manipulators.

Oerlikon Metco has paid extreme attention to the stability of operating conditions to maximize production, while minimizing service requirements. Long-standing experience in the design of HVOF equipment for thermal spray is your insurance this equipment can be utilized with complete confidence. The WokaJet-410, WokaJet-410-S and WokaJet-410-Sz guns are designed to the latest safety codes and are CE conformant.



WokaJet-410-Sz Liquid-Fuel HVOF Spray Gun

## 1 General Description

The WokaJet series spray guns are designed for liquid fuel (kerosene) and oxygen operation. Fuel and oxygen are fed into the rear part of the gun, atomized by a mixer head and combusted in the combustion chamber as the heat source for the coating process. Spray powder from the powder feeder is fed radially into the gun through two powder ports into the gas stream. The spray stream is accelerated through a converging / diverging nozzle to several times that of the speed of sound. The spray particles are heated to a molten or semi-molten state and propelled at high velocity, impacting the coating surface in a plastic state.

The long barrel optimizes the dwell time of the spray particles in the jet stream, while minimizing particle dwell time in air. This results in dense, intrinsically bonded coatings that

exhibit low oxide content. HVOF spray using liquid fuel offers certain advantages over other processes, such as the easy availability and handling of fuel, and higher energy density associated with these hydrocarbons. The increased quantity of heat available results in denser coatings with higher bond strengths.

The robust design of WokaJet series guns offer improved durability yet produce coatings that equate favorably compared to other liquid fuel HVOF guns currently on the market. The wrought metal housing will withstand harsh spray environments, while nozzle nuts are constructed of steel to prevent warping and provide a safe and tight seal. The rear gun body connectors have been designed to provide years of trouble-free performance.

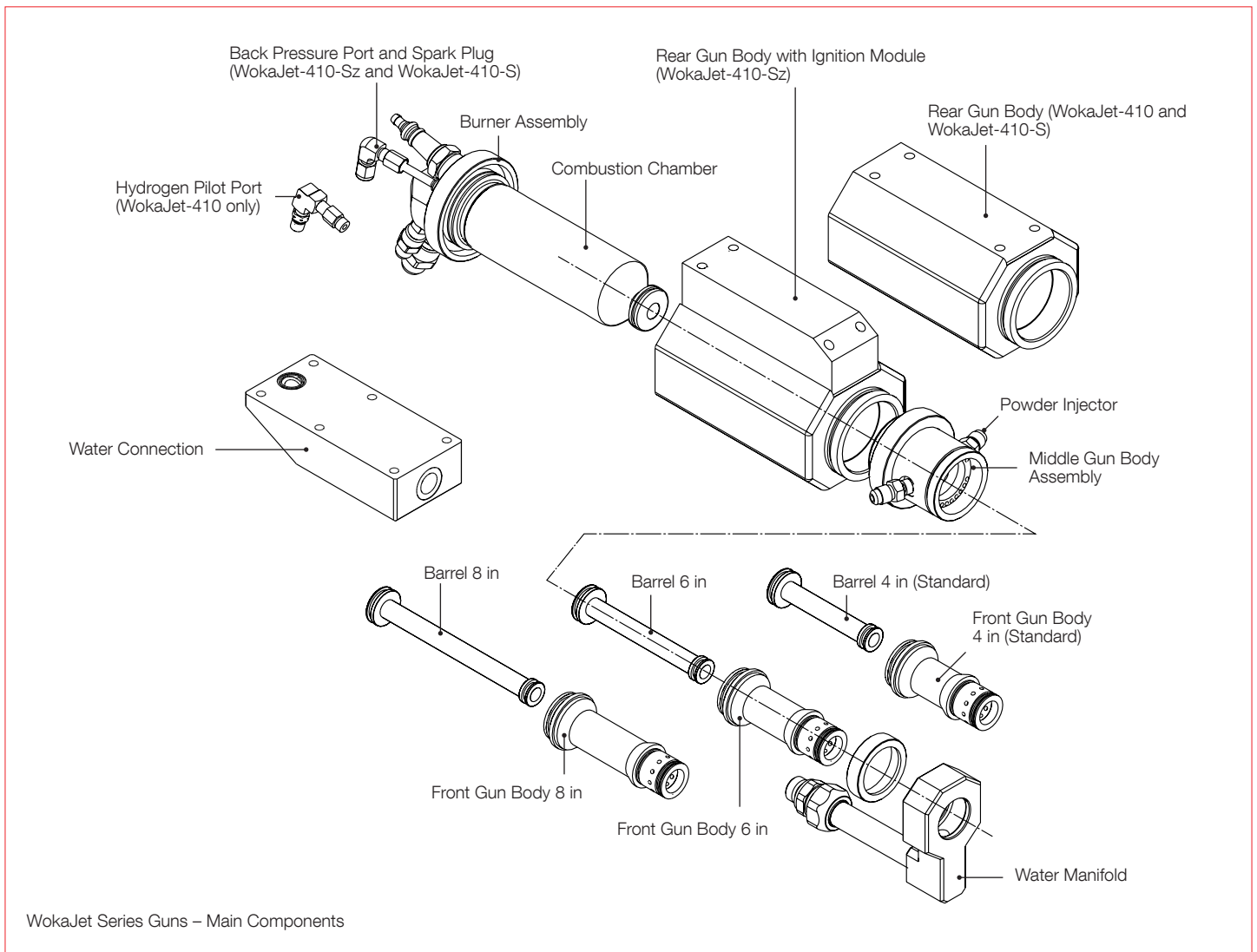

## 1.1 WokaJet Gun Series Comparison Chart

Gun Model	WokaJet-410	WokaJet-410-S <sup>a</sup>	WokaJet-410-Sz <sup>b</sup>
Ignition Type	Hydrogen	Spark Plug	Spark Plug
Controller Compatibility:			
UniCoatPro LF			●
MultiCoat HVOF <sup>c</sup>	●	▲	▲
UniCoat LF	●	▲	▲
UniCoat GLF <sup>c</sup>	●	▲	▲
JP5000, JP8000, K2		●	

<sup>a</sup> Ignition module located in the JAMBox

<sup>b</sup> Ignition module mounted on the gun

<sup>c</sup> Requires that the system is equipped with HVOF liquid fuel capability.

● Compatibility

▲ Use with MultiCoat HVOF, UniCoat LF or UniCoat GLF requires special cable option supplied by Oerlikon Metco Systems Engineering.

## 2 Features and Benefits

### 2.1 WokaJet Coatings

- Excellent wear resistance and extended longevity for costly parts and components
- Superior microhardness compared to other thermal spray technologies
- Outstanding adhesion to substrate, with the bond strength of some coatings typically exceeding 69 MPa (10000 psi)
- Very high density coatings with minimal porosity
- Low impurities and oxides when compared to low velocity flame combustion and air plasma processes
- Low to medium residual stresses within the coating structure, depending on spray material and component geometry
- Thick coatings, up to or exceeding 6 mm (0.25 in) are possible
- Smooth “as-sprayed” surface finishes
- Excellent machinability and surface finishes, with super finishing possible for harder coating materials
- Predictable coating chemistry

### 2.2 WokaJet Gun Hardware

- Low-cost process using liquid fuel (kerosene)
- Dual port, radially fed powder injection
- Constructed of rugged materials for long service life with minimal maintenance
- Different barrel lengths available for specific spray materials
- Modular design allows for easy maintenance
- Polished barrel design reduces internal build-up
- Safe, reliable spark ignition with WokaJet-410-Sz and WokaJet-410-S
- Machine-mount design for use with robots and traverses
- WokaJet-400 and WokaJet-400-S parameters can be used without modification with WokaJet-410 series guns

## 3 Accessories and Options

Oerlikon Metco offers a choice of options such as different barrel lengths to be used with specific spray powders, gun ignition using hydrogen gas or spark plug ignition. For a complete list of optional parts and spare parts, please refer to the parts lists section of the reference manual.

Oerlikon Metco offers a wide selection of Diamalloy™ and WOKA™ brand thermal spray materials optimized for the HVOF spray process. These include a variety of alloys, superalloys, blends and self-fluxing materials appropriate for many industrial applications and critical surfacing needs.

### 3.1 Optional Barrel and Front Gun Body Lengths

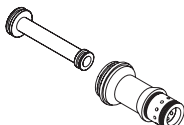
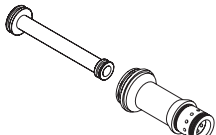
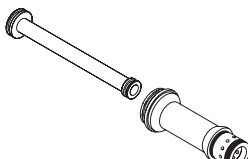
Gun Barrel and Front Gun Body	Length	Application
	101.6 mm / 4 in	Standard: Recommended for most coating parameters.
	152.4 mm / 6 in	Optional: Recommended when a longer dwell time is required, such as for spraying some carbides, coarse materials or when high spray rates are a necessity.
	203.2 mm / 8 in	Optional: Recommended for specialized applications where very long dwell times are required.

Note: Customers should use the shortest barrel length possible that achieves the desired coating results as the length of the barrel is directly proportional to the amount of loading (material build-up) in the barrel. However, this will vary for different materials and spray parameters.

### 3.2 Remote Ignition Module

Required to upgrade a WokaJet-410 gun to a WokaJet-410-S gun. This module can be mounted on a robot or other location. Note that additional cables and controller features are required.

### 3.3 Air Jet Assembly

Supplies cooling gas to the substrate while spraying. Air or any inert gas, such as CO<sub>2</sub> or N<sub>2</sub>, may be used as the cooling medium. Item No. 1051091.

### 3.4 Hose Assemblies

Includes water inlet and outlet hoses, oxygen and kerosene hoses to connect the gun to the controller. Available in 2 lengths:

Type	Length	Item No.
19H-25	8 m / 25 ft	1070914
19H-50	15 m / 50 ft	1070831

### 3.5 Electrical Connection Assemblies

Connects a WokaJet-410-S gun to UniCoatPro LF. Includes ignition device, ignition device supply cable, pressure transducer, pressure sensor cable and ground wire. Available in 2 lengths:

Length	Item No.
8 m / 25 ft	1070659
15 m / 50 ft	1070660

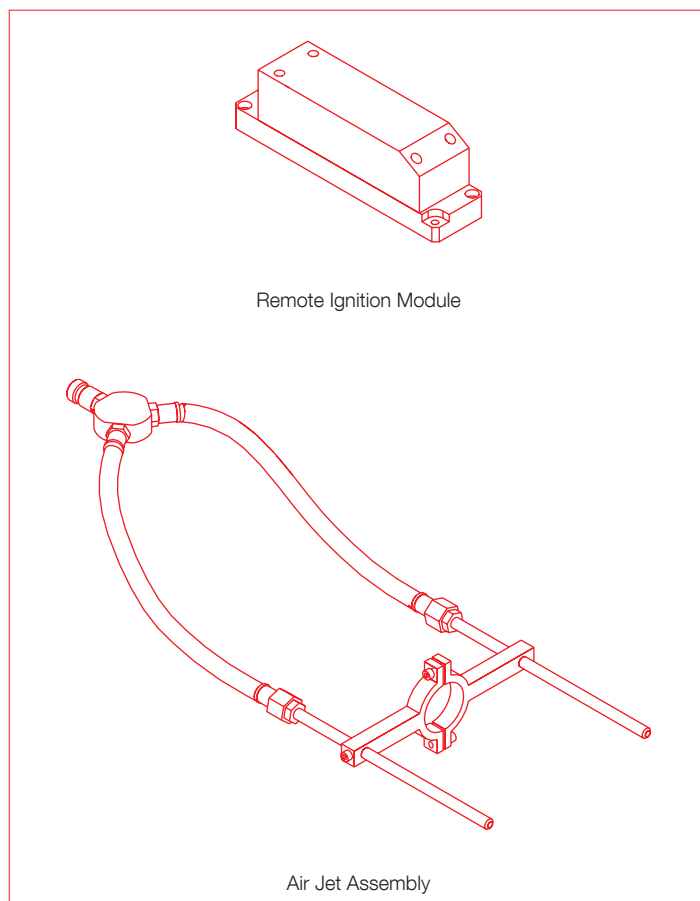

## 4 Technical Data

### 4.1 Dimensions

#### WokaJet-410-Sz:

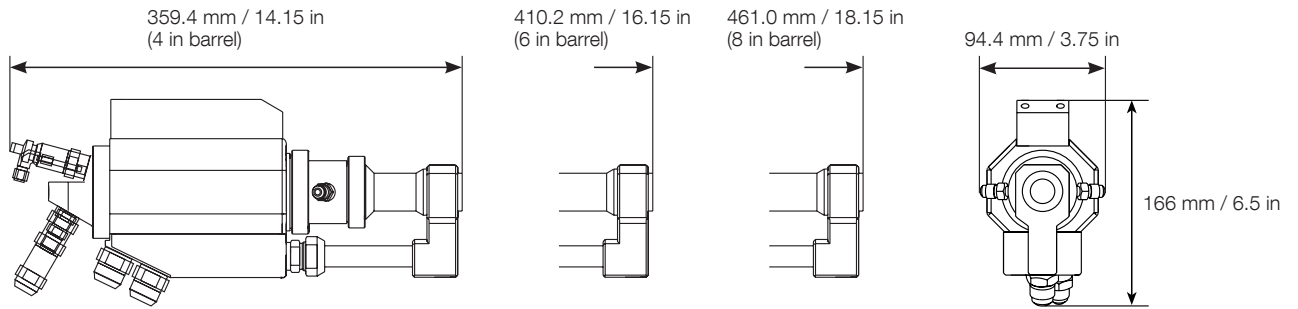

#### WokaJet-410-S:

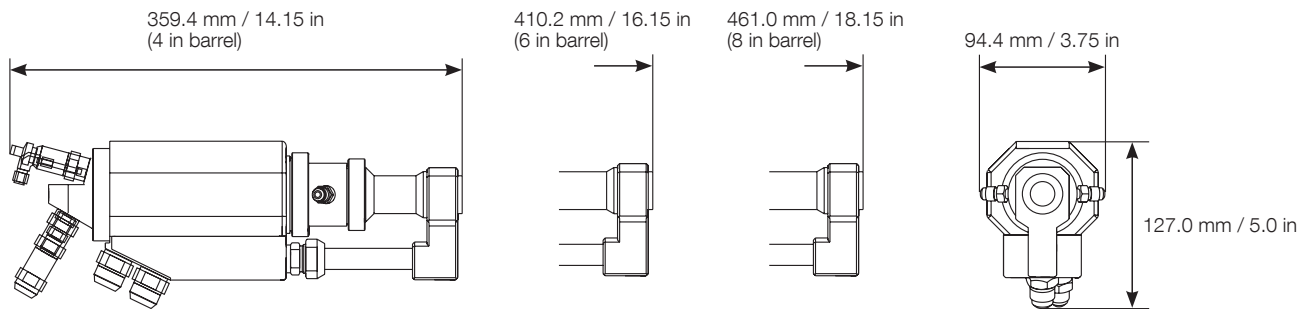

#### WokaJet-410:

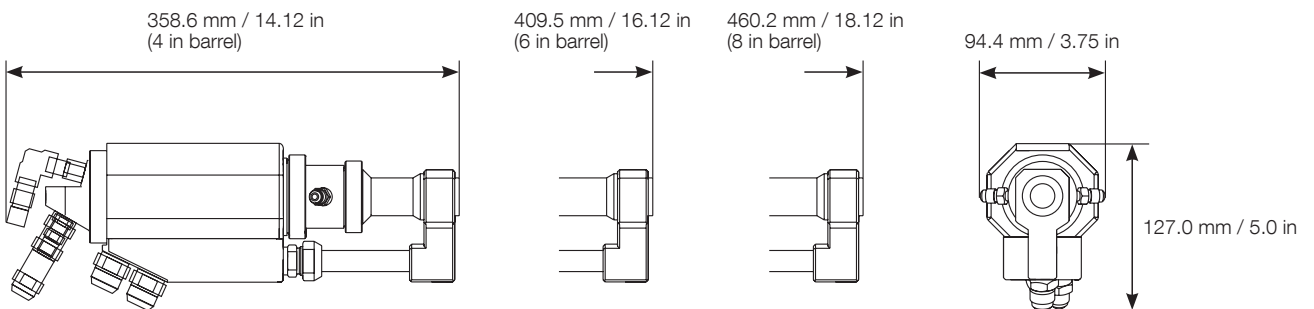

## 4.2 Specifications

### General Specifications

Particle velocity	550 to 720 m/s	1800 to 2360 ft/s
Combustion pressure	6.9 bar	100 psig
Total heat input	293 kW	1,000,000 BTU/h
Heat loss to water (cooling capacity)	93 kW	318,000 BTU/h
Heat output	200 kW	682,000 BTU/h
Recommended exhaust flow (min.)	15,000 m <sup>3</sup> /h	8750 ft <sup>3</sup> /min

### Process Media

Hydrogen – H <sub>2</sub>	Pressure	6.9 bar	100 psig
	Flow	88 NLPM	200 SCFH
Oxygen – O <sub>2</sub>	Pressure	17 bar	250 psig
	Flow	1100 NLPM	2500 SCFH
Nitrogen – N <sub>2</sub> (carrier gas)	Pressure	12.1 bar	175 psig
	Flow	18 NLPM	400 SCFH
Kerosene	Pressure	17 bar	250 psig
	Flow	32.2 l/h	8.5 gal/h
Compressed Air	Pressure	5.5 bar	79 psig
	Flow	500 NLPM	1140 SCFH

### Weight

	4.9 kg	10.8 lb
--	--------	---------

### Water Requirements

Pressure	14 bar	200 psi
Flow (min.)	39 l/Min	10 gal/min
Inlet temperature (max.)	24 °C	75 °F
Quality	< 40 µS Potable (drinking water)	

### Compatibility

Controllers	For use with WokaJet-410; WokaJet-410-S guns: MultiCoat HVOF, UniCoat LF, UniCoat GLF
	For use with WokaJet-410-Sz guns: UniCoatPro LF, MultiCoat HVOF
Powder feeders	For use with MultiCoat HVOF, UniCoat LF, UniCoat GLF systems: 9MPE-DJ-CL20, Single-120-H, Single-120-AH, Twin-120-H, Twin-120-AH, Single-220-H, Single-220-AH, 5MPE-HP
	For use with UniCoatPro LF systems: Twin-140, 5MPE-HP, 9MPE-DJ

Specifications indicate the maximum output of the spray gun. Most controller platforms have lower output capabilities.