

Solutions Flash

Improve efficiency and reduce emissions with high pressure turbine abradable coatings for industrial gas turbines

SF-0015.1 – October 2014



Today's situation

Driven by rising fuel prices and more stringent regulations for reduction of emissions, manufacturers of industrial gas turbines are under ever-increasing pressure to improve efficiency. Even a modest efficiency gain can produce significant results: Just a 1 % increase in efficiency for the worldwide 2500 GW installed electricity base leads to a 300 million metric tonnes (660 million pounds) CO₂ reduction and savings of 100 million metric tonnes (220 million pounds) of fossil fuel¹.

One area where such efficiency gains can be achieved is through reduction in the clearances between rotating and stationary components in the gas path. In the compressor

The Oerlikon Metco solution

Oerlikon Metco, the leading supplier of abrasible solutions for IGT and aero compressor applications, has developed a portfolio of ceramic abrasible materials for hot section applications. Oerlikon Metco's solutions have been designed such that the abrasible coatings are cut cleanly by tipped blades, and in some applications, can be used to rub against untipped blades.

These abrasible solutions have been tested, and have been proven to increase overall engine efficiency by > 1 % when applied to 1st stage HPT shrouds operating at temperatures up to 1150 °C (2100 °F)². Furthermore, the erosion resistance of these coating solutions will last, and continue to function as designed throughout the time between overhauls.

Moreover, Oerlikon Metco can provide a complete solution package, that either includes materials and the spray system, or services to apply the coatings on customer-supplied parts. In addition, we have expert material technologists to consult on specific requirements, as well as component testing facilities that closely match the actual service conditions for tip velocity, incursion rate and operating temperature.

Leading turbine OEM's have already incorporated Oerlikon Metco's HPT abrasible technology into production turbines, with very satisfactory results. These solutions are highly cost effective, and in those applications where they can be used against untipped blades, the cost benefits are even greater as the expensive tipping process is eliminated.

section, the use of passive clearance control through the application of thermal sprayed abrasible coatings has been highly successful and is widely used in both aero and industrial gas turbines. However, the coatings traditionally used in the compressor will not withstand the high temperatures of the turbine.

Ceramic materials would be desirable for hot section clearance management; however, standard ceramic coatings, such as stabilized zirconia materials, can cause severe damage, even to blades tipped with cBN, should an incursion occur.

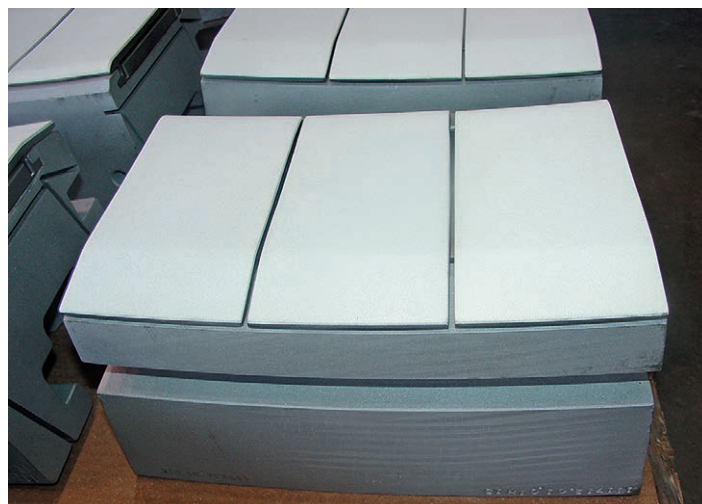

Oerlikon Metco's ceramic abrasible solutions, applied to 1st stage HPT shroud segments, are proven to increase overall efficiency by > 1 %.

¹ Information Brochure issued by the European Association of Gas and Steam Turbine Manufacturers hosted by VDMA; EUTurbines (2008).

² "Increased Efficiency of Gas Turbines," Sulzer Technical Review, edition 2/2008, D. Sporer, A. Refke, M. Dratwinski, M. Dorfman, I. Giovannetti, M. Giannozzi, M. Bigi

Validation

Area of application and abrasability mechanism

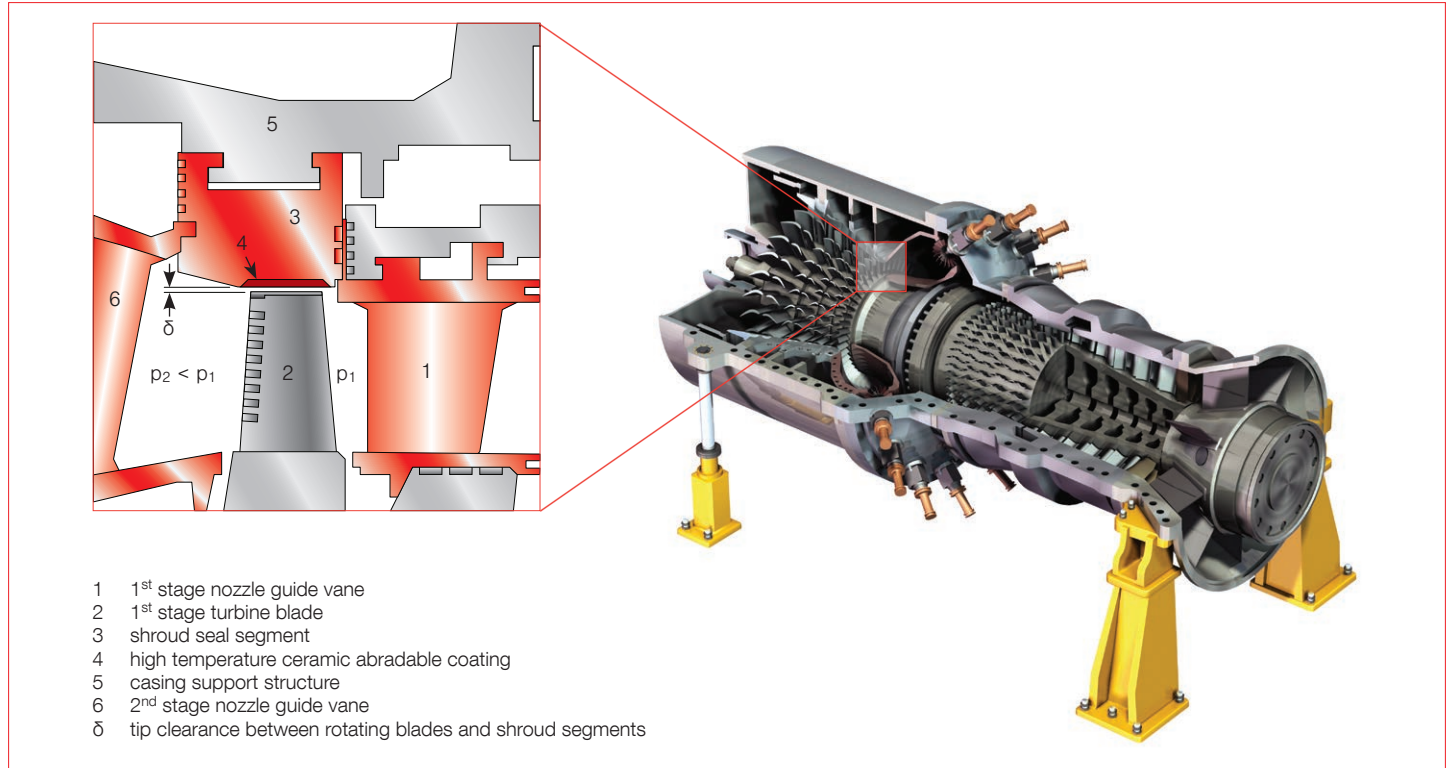

The abrasible ceramic seal materials are comprised of the ceramic matrix, a fugitive phase to control porosity and a release agent which enhances abrasability. They are applied using atmospheric plasma spray such that porosity, erosion

and hardness are controlled. The ceramic coating is applied over a compatible MCrAlY bond coat material. Here, too, Oerlikon Metco has a large portfolio of MCrAlY bond coat materials.

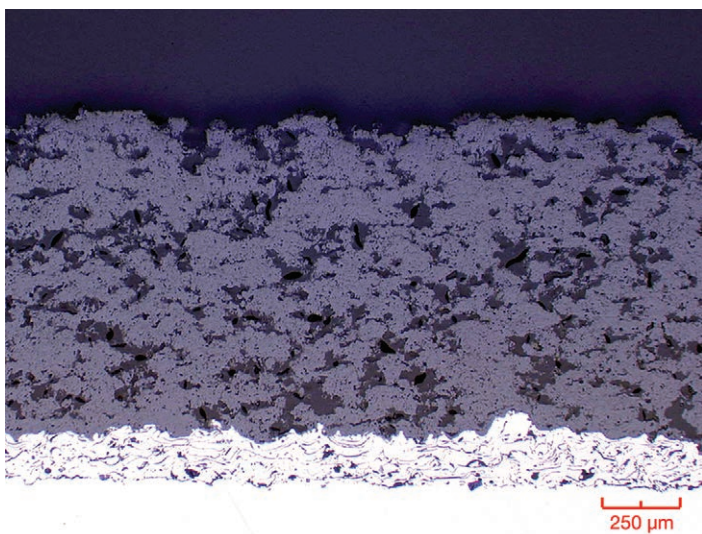

Typical microstructure of a high temperature ceramic abrasible, shown over an MCrAlY bond coat material.

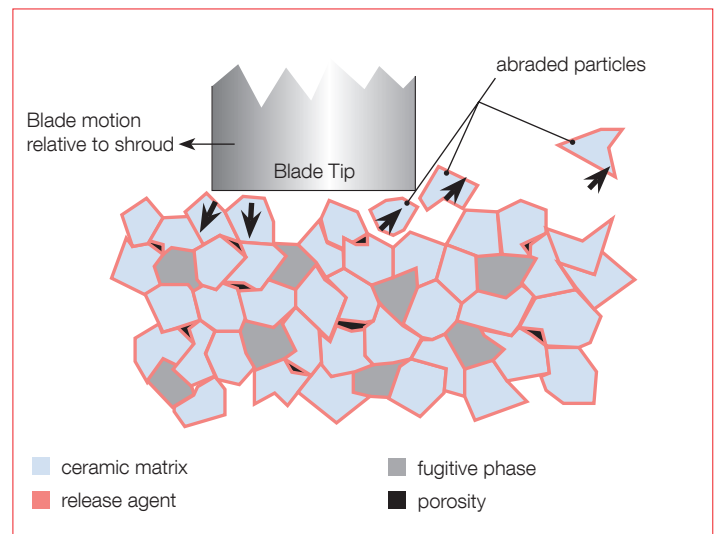

Schematic representation of the abrasible mechanism in service.

Rotor rub event

In the event of a rub on an engine without the abrasible coating (case A), blade wear and damage is likely to occur. As a result the gas path clearance becomes larger than the design clearance.

On an engine with an abrasible coating (case B), the blades cut cleanly into the abrasible. Wear and damage to the blades are minimal or eliminated, and the gas path clearance remains as designed. Because the abrasible manages the clearance, the hot-running clearance can be considerably smaller than without the abrasible, thereby increasing efficiency.

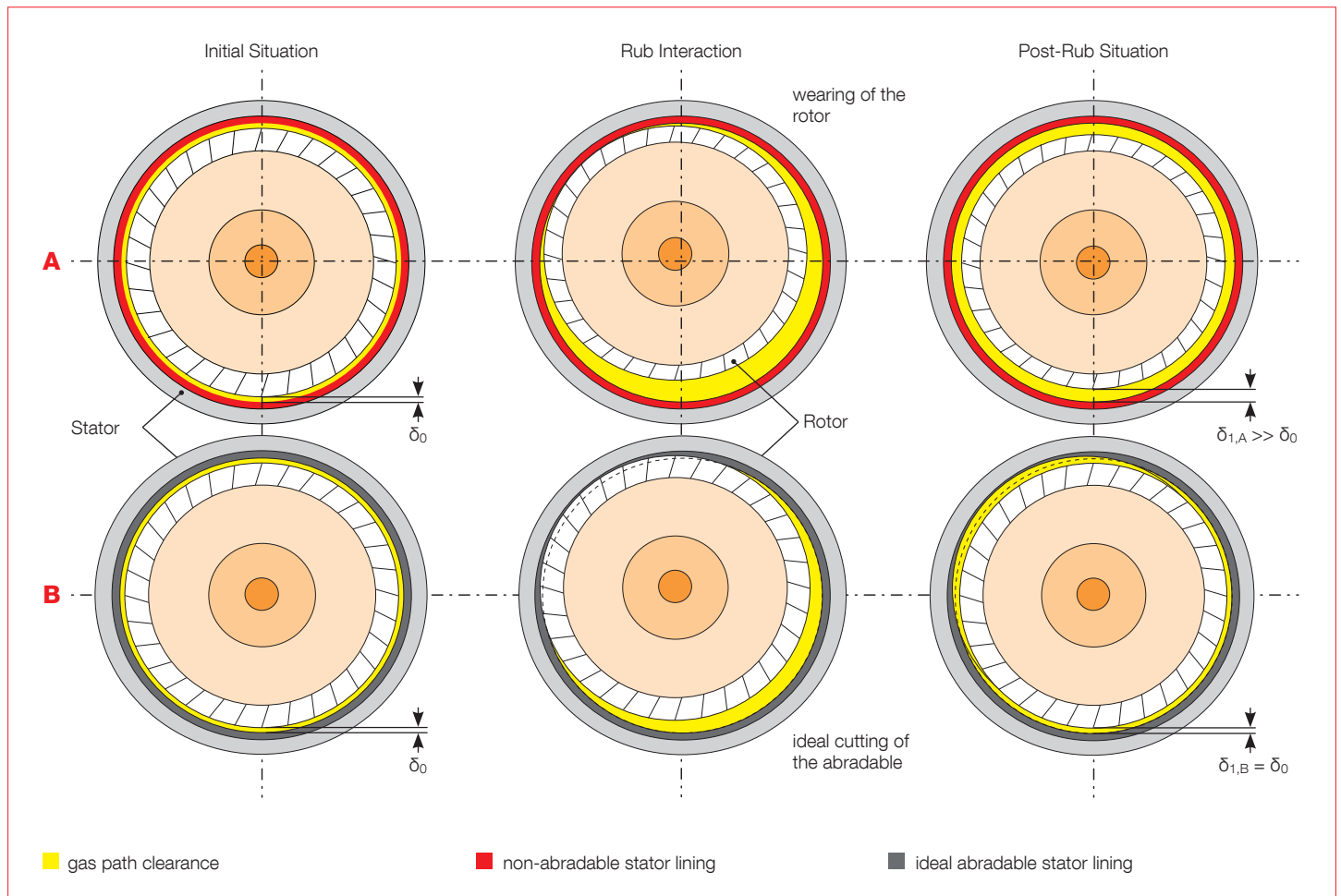

Oerlikon Metco ceramic abrasible materials

The Oerlikon Metco family of ceramic abrasible materials for high-temperature HPT applications have been extensively tested over a wide variety of rub conditions. Coatings of these materials have been proven to have excellent abrasibility characteristics, with minimal blade wear. Coating

parameters can be adjusted to control porosity levels, hardness and erosion resistance (higher porosity lowers hardness and erosion resistance). Furthermore, the polymer fugitive phase can be easily removed with a post-coat heat treatment, if desired. Nominal compositions for these products are shown below.

Material	ZrO ₂	Y ₂ O ₃	Dy ₂ O ₃	Polymer	Binder	hBN	Manufacturing Method
Durabrade 2192	Bal.	–	9.5	4.5	–	0.7	HOSP & Blend
Metco 2395	Bal.	7.5	–	4.5	–	0.7	HOSP & Blend
Metco 2460	Bal.	7.5	–	4.0	4.0	–	Spray Dry

Component testing of the abradable system using the Oerlikon high-temperature abrasability test rig

Using our component testing facilities, Oerlikon Metco can generate wear maps that validate the correct abrasability under a range of conditions. These include tip speed, incursion rate and temperature.

The test rig consists of a rotating test blade (tipped or un-tipped) and a stationary test shroud segment coated with the

abradable system. For each sample, the rub mechanism is evaluated and wear maps generated.

Test rig parameter range:

- Blade tip velocity: max 410 m/s (1345 ft/s)
- Incursion rate: 1 – 2000 $\mu\text{m/s}$ (39 – 78740 $\mu\text{in/s}$)
- Shroud temperature: 20 – 1200 °C (68 – 2192 °F)

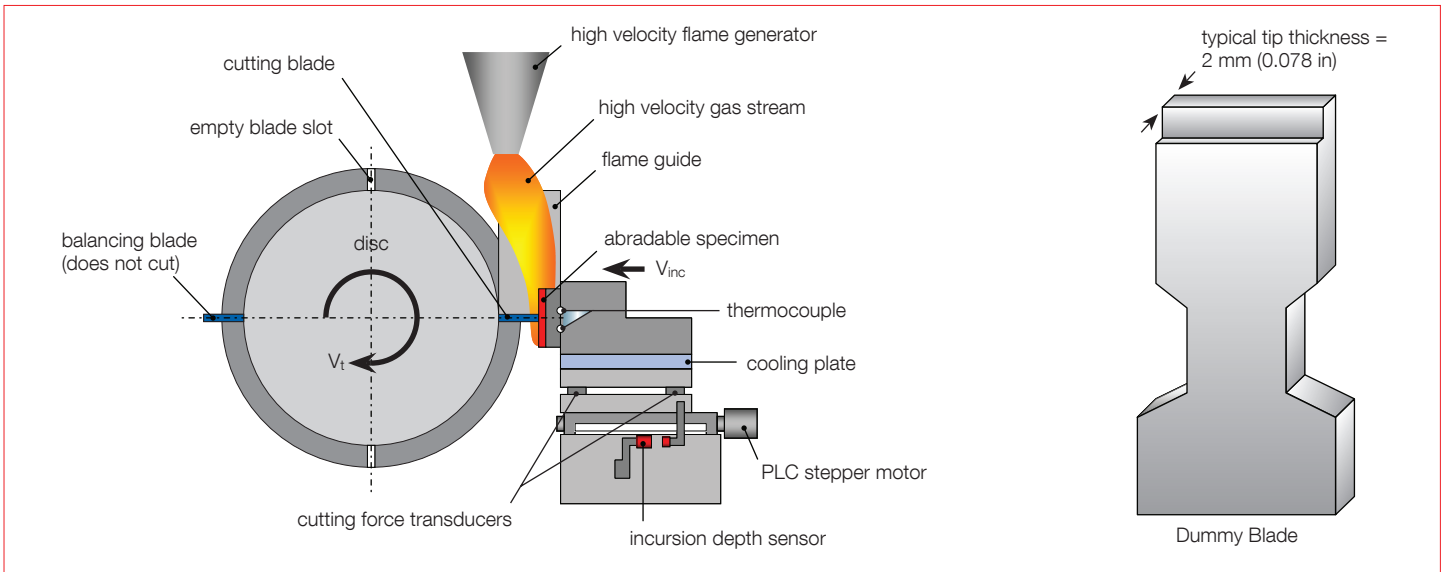

High Temperature Abradability Test Rig

Wear map generation

While the expected blade tip speeds for rub interactions in engines can be estimated with some certainty, the corresponding incursion rates are mostly not known. Therefore a general screening test makes use of a standard wear map consisting of five different tip speed/incursion rate pairings.

When combined with various coating microstructures, the results from these wear maps are a powerful tool for determining ideal abrasability to meet the specific design requirements.

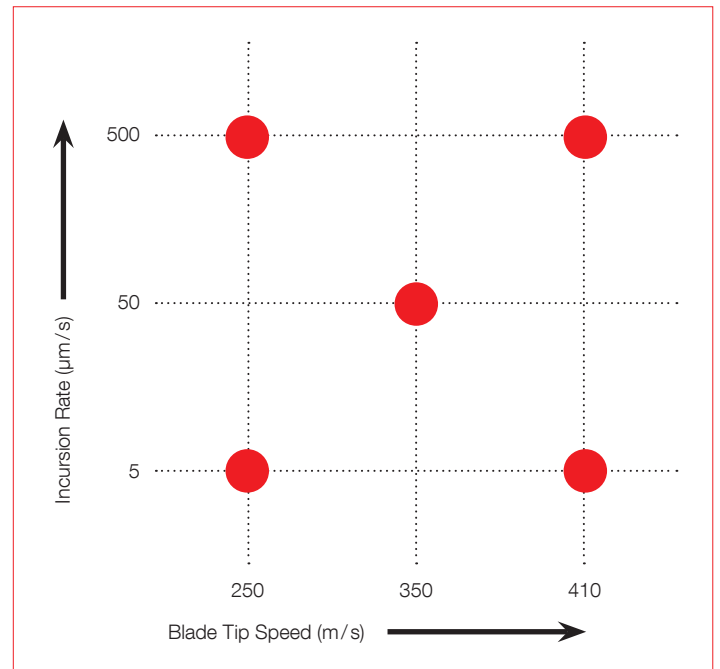

Standard 5-Point Wear Map
 Typical total incursion = 0.7 mm (0.028 in)
 Standard blade material IN 718 (bare/tipped)

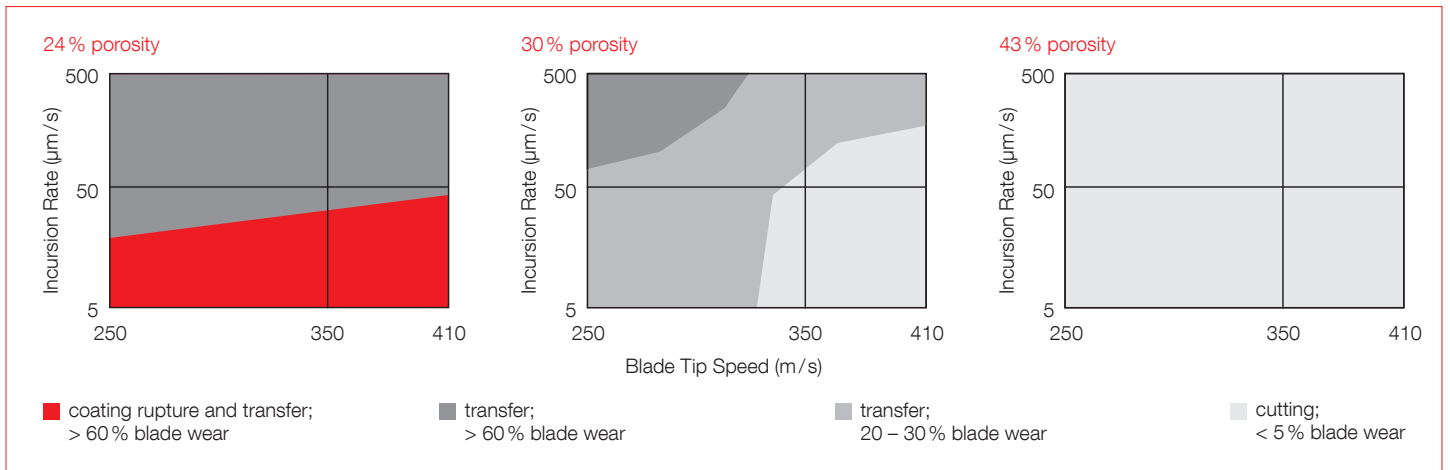

Sample abrasible wear map results at varying levels of porosity against untipped blades

Good abrasibility results

Rubs that demonstrate good abrasibility exhibit clean cutting action of the blade into the abrasible coating, with no or minimal blade wear (note: blade wear is reported as a percentage of total incurSION depth).

the ceramic seal. The transferred metal forms a hard, oxidized deposit on the ceramic surface and typically prevents clean cutting of the abrasible as a result of the metal tip now rubbing against a dense metal layer.



Examples of cleanly cut ceramic abrasible coatings @ 1100 °C (2012 °F). Left: against an un-tipped blade, Right: against a cBN tipped blade



Heavy coating rupture after initial blade material transfer



Coating rupture



Slight coating rupture mixed with cutting and some blade material transfer

Poor abrasibility results

While high blade wear is normally always indicative of sub-optimal abrasibility, low blade wear does not necessarily mean optimal abrasibility performance as the seal coating may show macrorupture. Such coating rupture may cause large and deep pockets of the seal to be removed early in the rub process and leave no or little material behind for subsequent blade passes to cut into, thereby feigning small blade wear.

Another typical but unfavorable wear mechanism observed for ceramic abrasibles is material transfer from the blade to



Mixed coating rupture and blade material transfer

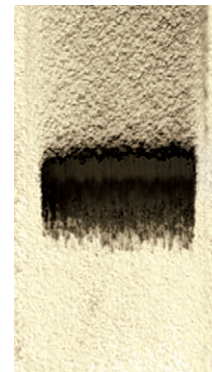

Heavy blade material transfer

Effects of coating porosity

In service, coating performance is a balance of abrasability and durability, in terms of erosion resistance and thermal shock. Coatings that qualify to the design requirements in terms of abrasability are then tested for erosion resistance. Those coatings that meet both can be considered qualifying candidates for an abrasable solution.

Varying levels of porosity can be achieved in a controlled and reproducible manner through adjustment of the spray parameters. As can be seen from the graph below, all material offerings are good candidates for tipped blades. Durabrade 2192 is also a good candidate for un-tipped blades.

Thermal behavior

Because these coatings have a high-temperature, high-quality ceramic matrix, they have inherently good thermal resistance. However, as with all abrasable coatings, the ceramic top coat must be sprayed relatively thick to accommodate the potential incursion depth. A top coat thickness in excess of 1 mm (0.04 in) is typical. While this has a beneficial effect of thermally insulating the shroud, it is detrimental to thermal cycle longevity. Typically, the cyclic life is drastically reduced with increasing coating thickness. This can be balanced to

some extent by higher porosity levels. When very thick coatings are required at the highest temperatures, the use of alternative zirconia stabilizers, such as dysprosia in Durabrade 2192, has shown that thermal shock properties of coatings can be improved by up to four-fold, particularly when the requirements indicated that a porosity level of greater than 25 % is required.

Make or buy – it's your decision

As the worldwide leader in thermal spray technologies, Oerlikon Metco offers customers flexibility for their coating implementation. Oerlikon Metco can provide the abrasable materials, or a complete coating facility solution that consists of the abrasable materials, state-of-the-art, efficient spray systems custom-designed for the components to be sprayed and technology transfer that includes training and support for optimal and consistent processing results. However, not all customers desire such a solution. We therefore offer expert coating application services through our network of worldwide service centers. These service centers are well-respected for their attention to detail and quality of production. Whatever your decision, your abrasable coating solution will exceed your expectations.

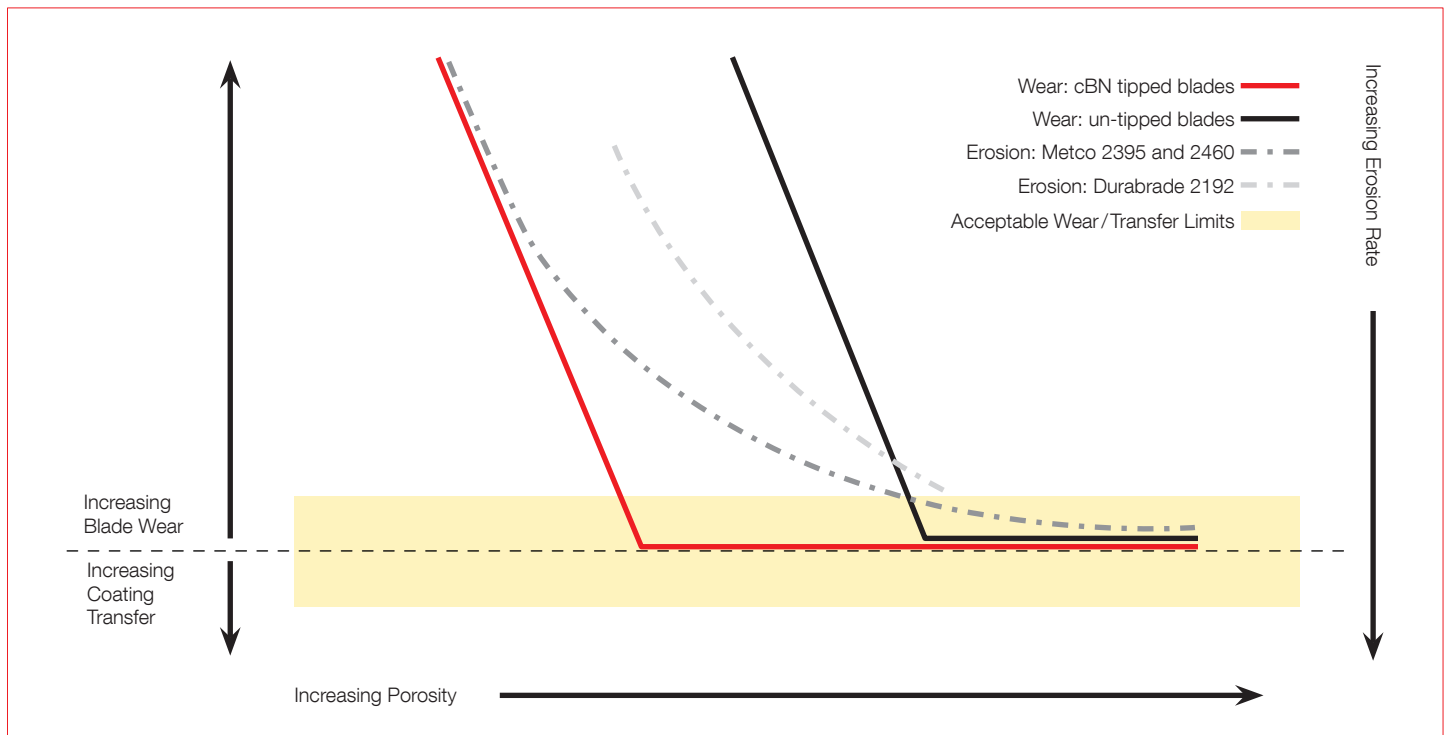

Customer benefits

Environmentally friendly

- Significantly reduces engine emissions.

Efficient

- Can increase overall engine efficiency by > 1 % when applied to 1st stage HPT shrouds.
- Solutions available for customers who wish to apply coatings in-house or coating service solutions for customers who prefer to out-source.

Economical

- Economical process with high return on investment.
- Thermal insulation properties can extend the life of shroud segments or allow incorporation of lower cost shroud segment materials.
- Minimal blade wear can extend life of blading.
- Depending on the design approach, expensive blade tipping can be eliminated.

Effective

- High-temperature abrasion-resistant coating systems effectively manage clearances in the HPT section of industrial gas turbines.
- Ceramic abrasion-resistant solutions operate at temperatures up to 1150 °C (2100 °F) with optimized thermal cyclic life.
- Durabrade 2192 uses a dysprosium stabilizer combined with a high-purity ceramic matrix for significantly enhanced coating cyclic life.
- Choice of materials combined with flexible, reproducible coating parameters allows design of an abrasion-resistant system to meet specific operating requirements.
- State-of-the-art materials technology for coatings that result in very minimal blade wear during rub interactions and maintains hot-running gas-path clearances.